

Dry-type Transformer

# High Reliability Maintenance Free

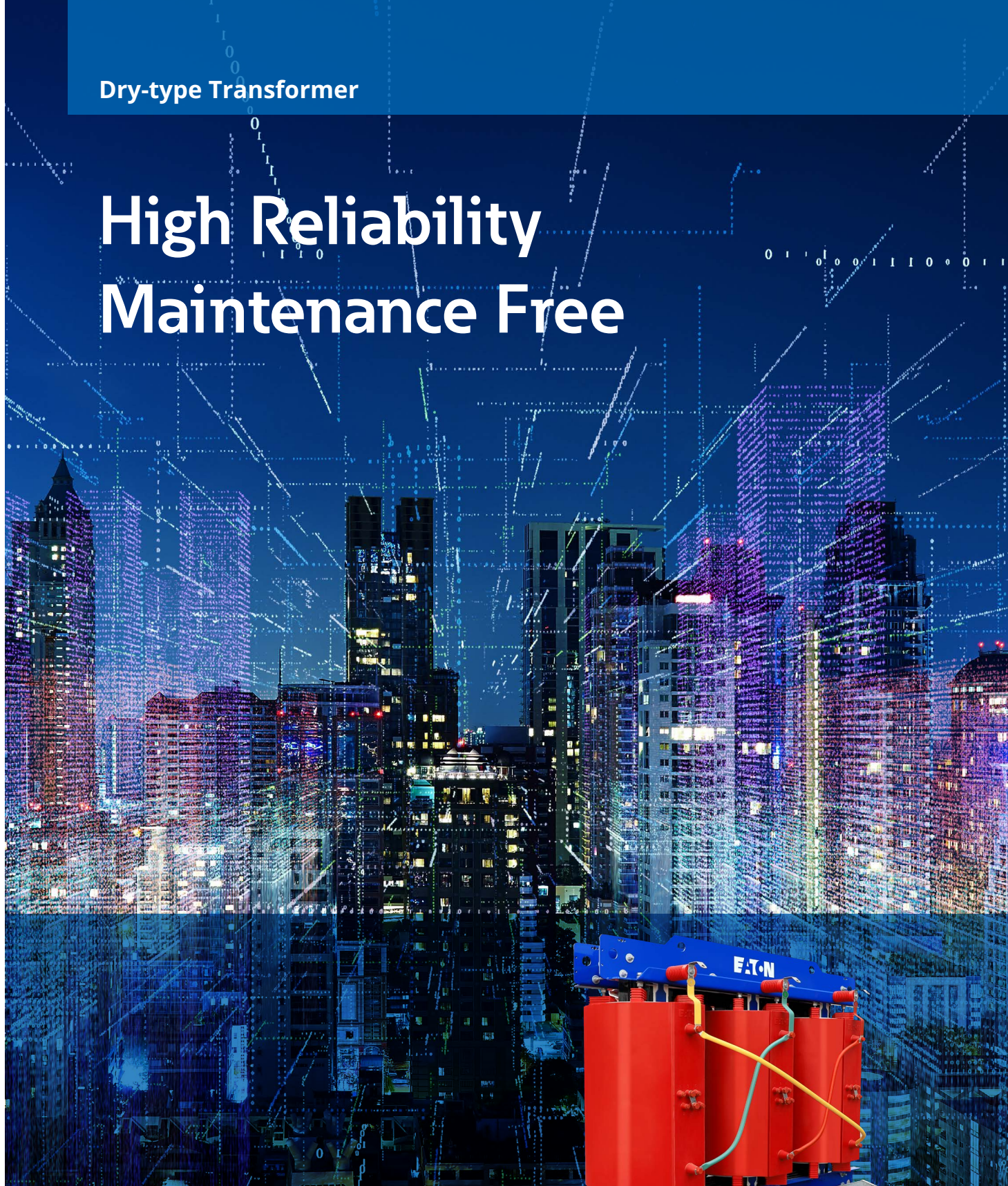

**EATON**

*Powering Business Worldwide*



**PT. APINDO MITRA SELARAS**

Telp. +62 821 2222 8303 - [aris@kseindonesia.com](mailto:aris@kseindonesia.com)  
[sales@kseindonesia.com](mailto:sales@kseindonesia.com) - [www.kseindonesia.com](http://www.kseindonesia.com)

**Eaton's vision is to improve quality of life and the environment through the use of power management technologies and services.**

- We are dedicated to developing our employees by helping them succeed not just at work, but in life as well.
- We delight our customers by understanding their challenges and proactively delivering real solutions.
- We deliver for our shareholders by doing what's right, so investors want to own more shares in our company.
- We support our communities by providing products and solutions that can improve quality of life and the environment; we also offer our time, talent and resources to satisfy social and economic needs where we work and live.



**ETN**  
**LISTED**  
**NYSE**

## Eaton

Eaton is an intelligent power management company dedicated to improving the quality of life and protecting the environment for people everywhere. We are guided by our commitment to do business right, to operate sustainably and to help our customers manage power - today and well into the future. By capitalizing on the global growth trends of electrification and digitalization, we're accelerating the planet's transition to renewable energy, helping to solve the world's most urgent power management challenges, and doing what's best for our stakeholders and all of society.

Eaton was founded in 1911 and has been listed on the New York Stock Exchange since 1923. We reported revenues of \$20.8 billion in 2022 and serve customers in more than 170 countries. Eaton entered the Chinese market in 1993 and has grown significantly since then. In 2004, Eaton moved its Asia-Pacific headquarters from Hong Kong to Shanghai. Today, Eaton has nearly 9,000 employees and 20 manufacturing facilities in China. Eaton is marking its 100th anniversary of being listed on the New York Stock Exchange, and its 30th anniversary of being in Chinese market.

### Electrical Sector

- Power distribution and circuit protection
- Power quality, backup power and power storage
- Safety and security
- Structural solutions
- Control and automation
- Solutions for harsh and hazardous environments

2022 SALES  
**\$ 14.3** BILLION

### Industrial Sector

- Aerospace
- Filtration
- Vehicle
- eMobility vehicle electrification

2022 SALES  
**\$ 6.4** BILLION

SALES  
**\$ 20.8** BILLION

NET INCOME  
**\$ 2.5** BILLION

EARNING PER SHARE  
**\$ 6.14** PER SHARE

# Focused and professional

**DATA CENTER**

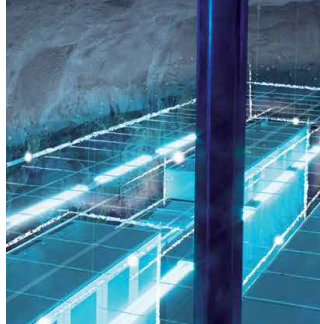

**ALTERNATIVE ENERGY**

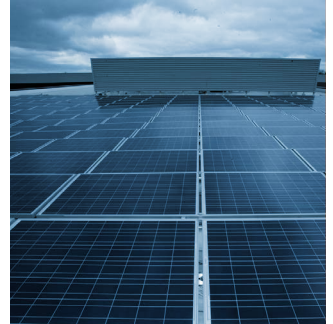

**FACILITIES**



**INFRASTRUCTURE**

**INDUSTRY**



**MACHINERY OEM**



**Eaton's Electrical Sector provides customized comprehensive services by:**

- Providing data centers with efficient and safe energy-saving solutions to protect your information and data.
- Providing photovoltaic, wind power, and hybrid solutions to help you convert new energy into daily power.
- Improving the reliability and uninterrupted running time of smart grids.
- Providing continuous, clean, reliable power and life cycle management services to improve project efficiency.
- Helping enterprises to reduce operating costs and complexity, enhancing the predictability of operational failures, and ensuring personnel safety.
- Assisting production equipment manufacturers in making machinery production management simpler, more reliable, safer, and more energy-efficient

## Eaton Dry-type Transformer

A legacy of classics with rapid response to customer demands



### In 1892

Eaton transformer technology can be traced back to 1892 in which the first dry type transformer was developed.

### For over a century

Eaton is committed to innovating and iterating transformers.

### In 2012

The acquisition of Cooper makes Eaton one of the world's leading manufacturers of electrical equipment.

### In 2023

Established in 2023

#### Eaton Transformer Jiangsu

Key products: **Dry type transformer, Oil immersed transformer, Prefabricated substation, Integrated power conversion and step-up unit**

### Full series of Eaton transformer solutions

- Complying with GB, IEC and UL standards
- Hundred years of technology heritage
- Customized manufacturing capabilities
- Rapid response to customer demands





# CONTENTS

## Dry-type Transformer

- Product Characteristics ..... 6
- Manufacturing ..... 7
  - Key Components ..... 7
  - Production Process ..... 8
- Optional Accessories ..... 9
- Quality Control ..... 10
- Product Report ..... 11
- Product Electrification Criteria ..... 12
- Design ..... 18
- Key Markets ..... 19

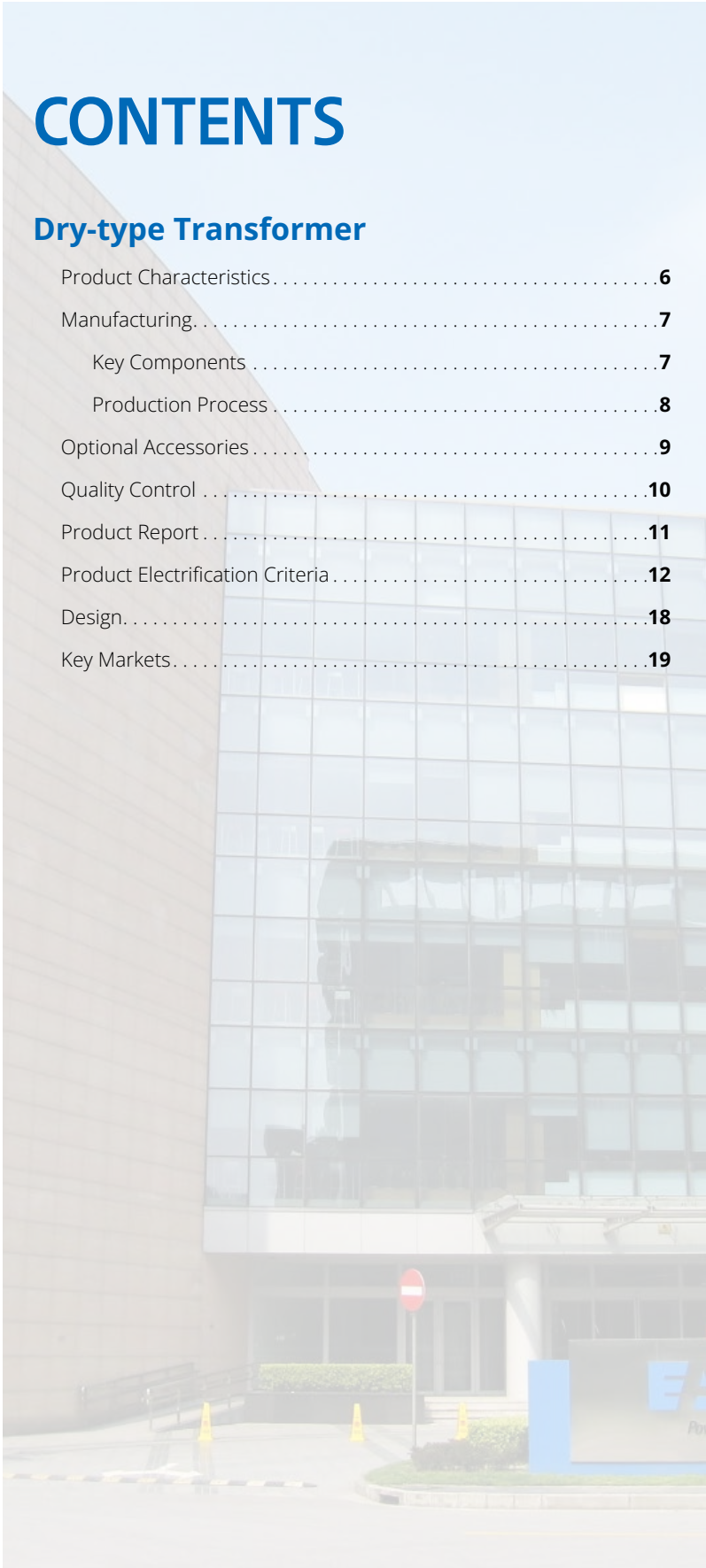

## Cast Resin Dry-type Transformer

### Scope

- **Voltage: Up to 35kV**
- **Rating : Up to 31.5MVA**
- **BIL : Up to 200kV**

### Key components

#### a. LV terminals

Standard arrangement: top  
Customization: bottom  
**(on the behind)**

#### b. Coil support system

To isolate core and winding from mechanical vibrations, reduce noise emission

#### c. HV terminals

Optimal layout schemes to adapt for various substations. HV tapping link can adjust itself to system voltage when power off

#### d. Clamping frame and truck

Made of steel plate and processed by laser cutting machine with high accuracy. Rollers can spin both horizontally and vertically

#### e. Core

Core sheet metal consist of low loss, cold rolled grain-oriented silicone sheets with extruded cores

#### f. Insulation cylinder

Reinforce insulation, improve the heat dissipation of transformer  
**(between the LV coil and HV coil)**

#### g. High Voltage Coil

High voltage coils are using copper and aluminum flat, round or band conductors covered with F class (H class optional) glass fiber. Windings are poured under vacuum using premium resin

#### h. Low Voltage Coil

Belt ( foil ) winding conductors are used in low voltage windings. F class(H class optional) insulation material is saturated in the resin and finally coils are hardened after winding process

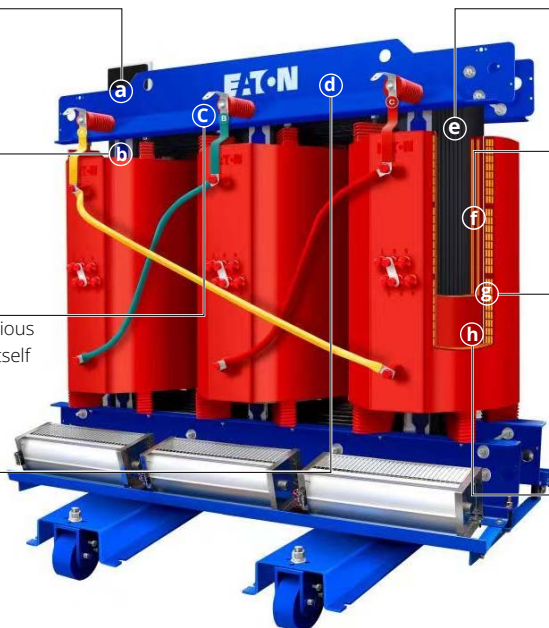

#### Safety

Safe, Non-flammable and self-extinguished



#### Climate-resistance

Working well even in extreme weather condition



#### Environment-friendly

100% dry structure guarantees zero environmental pollution



#### Convenience

Moisture resistant, and can operate in 100% humidity



#### Stability

Strong mechanical strength and short circuit withstand



#### High efficiency

Low loss, low partial discharge, low noise and good heat dissipation



#### Low cost

Maintenance free, easy to be settled and low operation cost



#### Innovation

World's leading three phase integrated 110kV cast resin dry-type transformer

## Key Components



### Core

The core material is made of high-quality cold-rolled grain-oriented silicon steel sheet (amorphous alloy core uses amorphous alloy material). The core adopts 45° fully oblique seam step-by-step lamination technology, the core-through screw pull plate structure, and the automatic stacking robot technology of silicon steel sheets to ensure the size alignment of the entire stack of silicon steel sheets and the lapping accuracy between sheets. High-quality materials and complete technology can effectively reduce the no-load loss and noise level. The outer surface of the core is coated with F-grade or H-grade black elastic two-component resin paint, which can effectively prevent dust and rust.

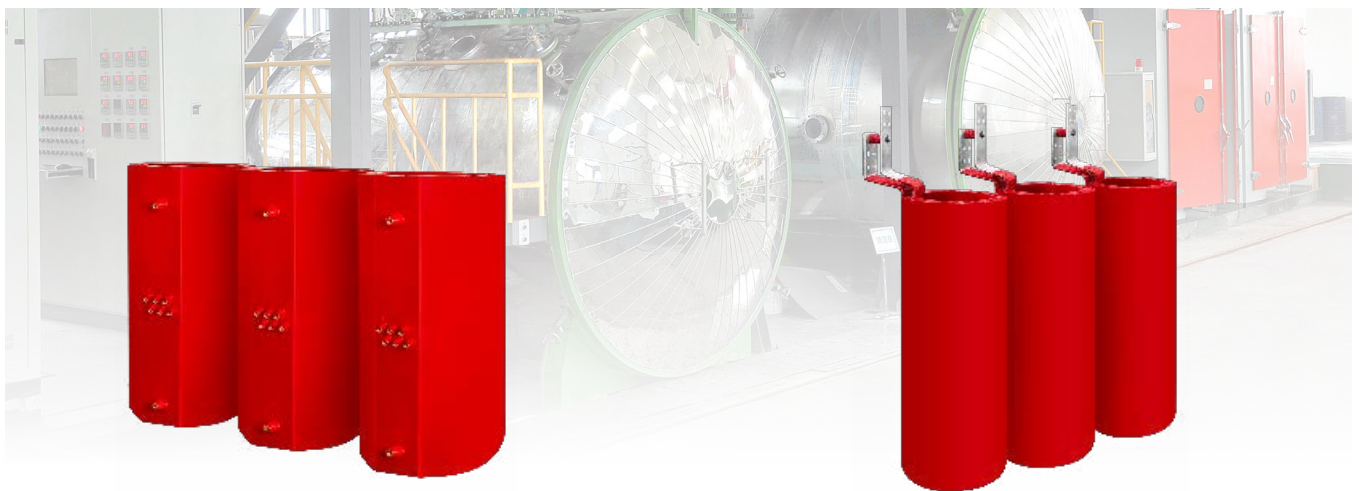

### HV winding

The HV winding adopts a cylindrical structure wound continuously with insulated copper wire and double-layer insulation. Under the vacuum state, the high-grade imported epoxy resin is used for overall high-temperature curing and molding. The mechanical strength after curing is very high, and the ultimate surface tensile stress can reach the strength of steel. The surface and air passage are very smooth, and it is difficult for dust to adhere to the coil surface.

### LV winding

The LV winding is made of a whole piece of round-edged copper foil. The interlayer is insulated with thermosetting epoxy prepreg cloth, which is cured at high temperature in a curing furnace. There is no helix angle at the end of the low-voltage foil winding coil, and the ampere-turn can be automatically balanced in the axial direction according to the distribution of the high-voltage coil, so that the short-circuit electromotive force can be reduced to a minimum in the case of a serious external short-circuit fault.

## Production Process



### Core automatic stacking equipment

The core is one of the key components of the transformer. Eaton adopts first-class equipment, advanced technology, and high-quality materials to ensure the quality of the core, which greatly reduces the no-load loss and noise of transformers.



### HV automatic winding machine

The HV coil automatic winding machine is controlled by a computer program and has the functions of constant tension and automatic winding. The HV coil is made of copper magnet wire, wound together with insulating materials such as glass fiber, and adopts a segmented cylindrical structure with low interlayer voltage and strong overvoltage resistance. Larger capacity coils are equipped with heat dissipation air passages, which have good heat dissipation performance.



### LV foil winding machine

The LV coil can be wound with electromagnetic wire, and Eaton also produces LV transformers with foil coils, which have the advantages of uniform electric field distribution and strong short-circuit resistance. LV foil coils are tightly wound with high-purity round-edged foil tape and insulation pre-impregnated with epoxy resin. The LV foil winding machine has the functions of constant tension, deburring, and automatic deviation correction.



### Resin vacuum casting system

After the finished coil is pre-dried, it is transferred to the pouring cabin of the epoxy resin vacuum casting equipment for vacuum drying to remove moisture and gas in the insulation. At the same time, materials such as epoxy resin and hardener are continuously degassed in an independent material preparation tank. After the processing process, the computer injects various chemical materials into the mold according to the set ratio through the precision metering system. After pouring, it is cured at high temperature in an oven, and finally made into a strong solid coil.

## Optional Accessories



### Cooling Fan

The transformer can be cooled by two modes: air natural cooling (AN) and air forced cooling (AF). Forced-air AF output of the transformer is up to 140% of the self-cooled rating, should be used only for emergency non-recurring loads, and but is not recommended for long-term running.



### Temperature Controller

The temperature is controlled by means of sensor provided on each transformer. The sensor (PT100) is installed in the LV winding. The digital controller shows the operating temperature of each LV winding, sequentially. The temperature controller performs the following functions of three-phase winding during transformer running: automatically switch the cooling fans on at 100°C and off at 80°C, it will send an over-temperature alarm at 130°C, and will send emergency shutdown trip signal at 150°C and sensor fault alarm.



### Steel-plate enclosure

The steel-plate enclosure is made of high-quality cold-rolled steel plate, which is processed by CNC shearing machine, CNC punching machine, and CNC plate bending machine. The steel plate shell has the advantages of beautiful and exquisite appearance, good ventilation performance, simple and quick installation, and convenient transportation. The color of the steel plate shell is RAL7032 computer gray or customized according to user requirements.



### Stainless steel enclosure

Stainless steel enclosure, the main material is stainless steel plate, which is beautiful and anti-corrosion, and can be easily assembled on site, with inspection doors on the front and back. The shell protection device provides a safety barrier for the live parts, and the protection level reaches IP20, IP23 and above. The IP20 casing can prevent the entry of solid foreign objects with a diameter greater than 12mm; the IP23 casing can also prevent the inflow of water droplets within 60° from the vertical line.

## Quality Control



Eaton quality control was carried out according to ISO9001 quality management standard and production standard, there are many quality engineers working for IQC, PQC, FQC and OQC. All transformers should be inspected and tested by operator, auditor and inspector according to the production standards and requirements before it been transported to the next production process, the failed product will be rejected. The product's quality and reliability are ensured by our strict management procedure, serious working attitude and advanced testing equipments.

## Transformer Inspection and Test Center



Impulse Test System







Insulation ratio DC resistance test equipment



Partial discharge laboratory

Test Item	Test Type	Test Item	Test Type
Winding resistance measurements	Routine test	Induced-voltage test	Routine test
Ratio and phase-relation tests	Routine test	Partial discharge measurements	Routine test
No-load loss and excitation current measurements	Routine test	Sound level measurements	Type test
Load loss and impedance measurements	Routine test	Lightning impulse test	Type test
Insulation resistance measurements	Routine test	Temperature rise test	Type test
Applied-voltage test	Routine test	Short-circuit withstand test	Special test

## Type Test Reports

实验室名称: 苏州电器科学研究院股份有限公司  
 国家电器产品质量检验检测中心  
 Lab Name: Suzhou Electrical Apparatus Science Research Institute Co., Ltd.  
 China National Center for Quality Inspection and Test of Electrical Apparatus Products

No 23N0265-S

### 型式试验报告 Type Test Report

委托单位: 伊顿变压器(江苏)有限公司  
 Client:

产品名称: 干式变压器  
 Name of Product:





产品型号: SCB18-2500/10-NX1  
 Product Type:

检验类别: 型式试验  
 Test Category:

本实验室对出具的检验(试验)结果负责, 未经实验室书面同意, 不得部分地复制本报告。

The laboratory is responsible for the inspection (Test) results. The report shall not be reproduced except in full, written approval of the laboratory.

SCB18-2500/10-NX1

实验室名称: 苏州电器科学研究院股份有限公司  
 国家电器产品质量检验检测中心  
 Lab Name: Suzhou Electrical Apparatus Science Research Institute Co., Ltd.  
 China National Center for Quality Inspection and Test of Electrical Apparatus Products

No 23N0261-S

### 型式试验报告 Type Test Report

委托单位: 伊顿变压器(江苏)有限公司  
 Client:

产品名称: 干式变压器  
 Name of Product:





产品型号: SCB18-1000/10-NX1  
 Product Type:

检验类别: 型式试验  
 Test Category:

本实验室对出具的检验(试验)结果负责, 未经实验室书面同意, 不得部分地复制本报告。

The laboratory is responsible for the inspection (Test) results. The report shall not be reproduced except in full, written approval of the laboratory.

SCB18-1000/10-NX1

实验室名称: 苏州电器科学研究院股份有限公司  
 国家电器产品质量检验检测中心  
 Lab Name: Suzhou Electrical Apparatus Science Research Institute Co., Ltd.  
 China National Center for Quality Inspection and Test of Electrical Apparatus Products

No 23N0263-S

### 型式试验报告 Type Test Report

委托单位: 伊顿变压器(江苏)有限公司  
 Client:

产品名称: 干式变压器  
 Name of Product:





产品型号: SCB14-2000/10-NX2  
 Product Type:

检验类别: 型式试验  
 Test Category:

本实验室对出具的检验(试验)结果负责, 未经实验室书面同意, 不得部分地复制本报告。

The laboratory is responsible for the inspection (Test) results. The report shall not be reproduced except in full, written approval of the laboratory.

SCB14-2000/10-NX2

实验室名称: 苏州电器科学研究院股份有限公司  
 国家电器产品质量检验检测中心  
 Lab Name: Suzhou Electrical Apparatus Science Research Institute Co., Ltd.  
 China National Center for Quality Inspection and Test of Electrical Apparatus Products

No 23N0259-S

### 型式试验报告 Type Test Report

委托单位: 伊顿变压器(江苏)有限公司  
 Client:

产品名称: 干式变压器  
 Name of Product:

产品型号: SCB14-500/10-NX2  
 Product Type:

检验类别: 型式试验  
 Test Category:

本实验室对出具的检验(试验)结果负责, 未经实验室书面同意, 不得部分地复制本报告。

The laboratory is responsible for the inspection (Test) results. The report shall not be reproduced except in full, written approval of the laboratory.

SCB14-500/10-NX2

# Product Electrification Criteria

## 10kV Class 100 ~ 3500kVA Distribution Transformer ( Copper Winding )

HV Voltage: 6kV/6.3kV/6.6 kV /10kV/10.5kV/11kV

LV Voltage: 400V/415V/420V/433V

Frequency: 50Hz/60Hz

HV tapping:  $\pm 2*2.5\%$  /  $\pm 5\%$

Vector group: Dyn11/Dyn5/Dyn1/Yyn0

Material of winding: Copper

Rated Power (KVA)	No-load Loss (kW)	On-load Loss 120°C (kW)	Short Circuit Impedance (%)	Noise (Lm-1) (dB)	No-load Current (%)	Base Frame Q1XQ2 (mm)	Weight (kg)	Outline Dimension (LengthxWidthxHeight) (mm)	Enclosure Dimension (IP20/IP21) (LengthxWidthxHeight) (mm)
100	0.40	1.57	4	47	1.5	550 × 660	640	1020 × 760 × 920	1600 × 1200 × 1400
125	0.47	1.85		48	1.3	550 × 660	700	1100 × 760 × 960	1600 × 1200 × 1400
160	0.54	2.13		49	1.3	660 × 660	860	1160 × 760 × 1000	1600 × 1200 × 1400
200	0.62	2.53		50	1.1	660 × 660	950	1200 × 760 × 1080	1600 × 1200 × 1400
250	0.72	2.76		50	1.1	660 × 660	1120	1240 × 760 × 1060	1600 × 1300 × 1500
315	0.88	3.47		50	1	660 × 660	1320	1300 × 760 × 1060	1600 × 1300 × 1500
400	0.98	3.99		50	1	660 × 660	1450	1400 × 760 × 1080	1800 × 1400 × 1600
500	1.16	4.88		50	1	660 × 660	1690	1480 × 760 × 1100	1800 × 1400 × 1600
630	1.34	5.88		50	0.85	660 × 660	2100	1500 × 760 × 1240	1800 × 1400 × 1600
630	1.30	5.96	6	50	0.85	660 × 660	1920	1580 × 760 × 1080	2000 × 1400 × 1800
800	1.52	6.96		51	0.6	820 × 820	2420	1680 × 920 × 1260	2000 × 1400 × 1800
1000	1.77	8.13		52	0.6	820 × 820	2760	1720 × 920 × 1340	2100 × 1400 × 1800
1250	2.09	9.69		54	0.5	820 × 820	3180	1780 × 920 × 1400	2100 × 1400 × 1800
1600	2.45	11.73		54	0.5	820 × 820	3960	1940 × 920 × 1420	2300 × 1500 × 2000
2000	3.05	14.45		56	0.5	1070 × 1070	4880	2000 × 1150 × 1580	2300 × 1500 × 2000
2500	3.6	17.17		60	0.5	1070 × 1070	5800	2120 × 1150 × 1680	2500 × 1600 × 2000
2000	3.05	15.96	8	56	0.5	1070 × 1070	4950	1930 × 1150 × 1630	2300 × 1500 × 2000
2500	3.6	18.89		60	0.5	1070 × 1070	5930	2080 × 1150 × 1780	2500 × 1600 × 2200
3150	4.28	22.46		62	0.5	1070 × 1070	7220	2180 × 1150 × 1840	2500 × 1600 × 2200
3500	4.63	24.31		64	0.5	1070 × 1070	8040	2250 × 1150 × 1900	2600 × 1600 × 2200

**Remark:** Eaton reserves the right to make changes or modify the contents of this catalogue without prior notice.

Eaton CRT can be designed and manufactured as per GB/IEC/ANSI standards.

## 10kV Class 100 ~ 3500kVA Distribution Transformer ( Aluminum Winding )

HV Voltage: 6kV/6.3kV/6.6kV/10kV/10.5kV/11kV  
 LV Voltage: 400V/415V/420V/433V  
 Frequency: 50Hz/60Hz

HV tapping:  $\pm 2 \times 2.5\%$  /  $\pm 5\%$   
 Vector group: Dyn11/Dyn5/Dyn1/Yyn0  
 Material of winding: Aluminum

Rated Power (KVA)	No-load Loss (kW)	On-load Loss 120°C (kW)	Short Circuit Impedance (%)	Noise (Lm-1) (dB)	No-load Current (%)	Base Frame Q1XQ2 (mm)	Weight (kg)	Outline Dimension (LengthxWidthxHeight) (mm)	Enclosure Dimension (IP20/IP21) (LengthxWidthxHeight) (mm)
100	0.40	1.57	4	47	1.5	550 × 660	580	1100 × 760 × 1040	1600 × 1200 × 1400
125	0.47	1.85		48	1.3	550 × 660	620	1180 × 760 × 1060	1600 × 1200 × 1400
160	0.54	2.13		49	1.3	660 × 660	790	1240 × 760 × 1100	1600 × 1200 × 1400
200	0.62	2.53		50	1.1	660 × 660	870	1280 × 760 × 1180	1600 × 1200 × 1400
250	0.72	2.76		50	1.1	660 × 660	1030	1320 × 760 × 1160	1700 × 1300 × 1600
315	0.88	3.47		50	1	660 × 660	1210	1340 × 760 × 1180	1700 × 1300 × 1600
400	0.98	3.99		50	1	660 × 660	1350	1420 × 760 × 1280	1800 × 1400 × 1700
500	1.16	4.88		50	1	660 × 660	1580	1500 × 760 × 1300	1800 × 1400 × 1700
630	1.34	5.88		50	0.85	660 × 60	1980	1530 × 760 × 1440	1800 × 1400 × 1700
630	1.30	5.96		6	50	0.85	660 × 660	1890	1600 × 760 × 1380
800	1.52	6.96	51		0.6	820 × 820	2230	1720 × 920 × 1560	2000 × 1400 × 1800
1000	1.77	8.13	52		0.6	820 × 820	2560	1740 × 920 × 1640	2100 × 1400 × 2000
1250	2.09	9.69	54		0.5	820 × 820	2980	1810 × 920 × 1720	2100 × 1400 × 2000
1600	2.45	11.73	54		0.5	820 × 820	3760	1920 × 920 × 1720	2300 × 1500 × 2000
2000	3.05	14.45	56		0.5	1070 × 1070	4580	2020 × 1150 × 1760	2300 × 1500 × 2000
2500	3.6	17.17	60		0.5	1070 × 1070	5560	2080 × 1150 × 1980	2500 × 1600 × 2300
2000	3.05	15.96	8		56	0.5	1070 × 1070	4750	1920 × 1150 × 1960
2500	3.6	18.89		60	0.5	1070 × 1070	5790	2080 × 1150 × 2020	2500 × 1600 × 2300
3150	4.28	22.46		62	0.5	1070 × 1070	6820	2180 × 1150 × 2080	2500 × 1600 × 2300
3500	4.63	24.31		64	0.5	1070 × 1070	7350	2250 × 1150 × 2150	2500 × 1600 × 2400

**Remark:** Eaton reserves the right to make changes or modify the contents of this catalogue without prior notice.  
 Eaton CRT can be designed and manufactured as per GB/IEC/ANSI standards.

# Product Electrification Criteria

## 20kV Class 200 ~ 3500kVA Distribution Transformer ( Copper Winding )

HV Voltage: 20kV/22kV/24kV

LV Voltage: 400V/415V/420V/433V

Frequency: 50Hz/60Hz

HV tapping:  $\pm 2 \times 2.5\%$  /  $\pm 5\%$

Vector group: Dyn11/Dyn5/Dyn1/Yyn0

Material of winding: Copper

Rated Power (KVA)	No-load Loss (kW)	On-load Loss 120°C (kW)	Short Circuit Impedance (%)	Noise (Lm-1) (dB)	No-load Current (%)	Base Frame Q1XQ2 (mm)	Weight (kg)	Outline Dimension (LengthxWidthxHeight) (mm)	Enclosure Dimension (IP20/IP21) (LengthxWidthxHeight) (mm)
200	0.73	2.94	6	50	1.1	660 × 660	1370	1380 × 760 × 1220	2000 × 1500 × 2000
250	0.84	3.42		50	1.1	660 × 660	1380	1400 × 760 × 1230	2000 × 1500 × 2000
315	0.97	4.08		50	1	660 × 660	1480	1430 × 760 × 1295	2000 × 1500 × 2000
400	1.15	4.84		50	1	660 × 660	1660	1480 × 760 × 1355	2000 × 1500 × 2000
500	1.35	5.79		50	1	660 × 660	1820	1490 × 760 × 1405	2000 × 1500 × 2000
630	1.53	6.84		50	0.85	660 × 660	2030	1540 × 760 × 1430	2000 × 1500 × 2200
800	1.75	8.26		51	0.6	820 × 820	2380	1590 × 920 × 1550	2000 × 1500 × 2200
1000	2.07	9.78		52	0.6	820 × 820	2740	1620 × 920 × 1570	2200 × 1650 × 2200
1250	2.38	11.5		54	0.5	820 × 820	3330	1710 × 920 × 1615	2200 × 1650 × 2200
1600	2.79	13.8		54	0.5	820 × 820	4070	1810 × 920 × 1680	2200 × 1650 × 2200
2000	3.24	16.3		56	0.5	1070 × 1070	5130	1940 × 1150 × 1765	2500 × 1800 × 2400
2500	3.87	19.3		60	0.5	1070 × 1070	6070	2030 × 1150 × 1885	2500 × 1800 × 2400
2000	3.24	17.8		8	56	0.5	1070 × 1070	5200	2000 × 1150 × 1795
2500	3.87	21.2	60		0.5	1070 × 1070	6200	2100 × 1150 × 1935	2800 × 1800 × 2500
3150	4.6	25.2	62		0.5	1070 × 1070	7380	2200 × 1150 × 1980	2900 × 1900 × 2600
3500	4.98	27.2	64		0.5	1070 × 1070	7990	2290 × 1150 × 2050	2900 × 1900 × 2600

**Remark:** Eaton reserves the right to make changes or modify the contents of this catalogue without prior notice.

Eaton CRT can be designed and manufactured as per GB/IEC/ANSI standards.

## 20kV Class 200 ~ 2500kVA Distribution Transformer ( Aluminum Winding )

HV Voltage: 20kV/22kV/24kV

LV Voltage: 400V/415V/420V/433V

Frequency: 50Hz/60Hz

HV tapping:  $\pm 2 \times 2.5\%$  /  $\pm 5\%$

Vector group: Dyn11/Dyn5/Dyn1/Yyn0

Material of winding: Aluminum

Rated Power (KVA)	No-load Loss (kW)	On-load Loss 120°C (kW)	Short Circuit Impedance (%)	Noise (Lm-1) (dB)	No-load Current (%)	Base Frame Q1XQ2 (mm)	Weight (kg)	Outline Dimension (LengthxWidthxHeight) (mm)	Enclosure Dimension (IP20/IP21) (LengthxWidthxHeight) (mm)	
200	0.73	2.94	6	50	1.1	660 × 660	1210	1450 × 760 × 1340	2000 × 1500 × 2000	
250	0.84	3.42		50	1.1	660 × 660	1250	1420 × 760 × 1340	2000 × 1500 × 2000	
315	0.97	4.08		50	1	660 × 660	1310	1440 × 760 × 1395	2000 × 1500 × 2000	
400	1.15	4.84		50	1	660 × 660	1470	1490 × 760 × 1470	2000 × 1500 × 2000	
500	1.35	5.79		50	1	660 × 660	1640	1530 × 760 × 1480	2000 × 1500 × 2000	
630	1.53	6.84		50	0.85	660 × 660	1890	1580 × 760 × 1525	2000 × 1500 × 2200	
800	1.75	8.26		51	0.6	820 × 820	2170	1630 × 920 × 1570	2000 × 1500 × 2200	
1000	2.07	9.78		52	0.6	820 × 820	2680	1720 × 920 × 1640	2200 × 1650 × 2200	
1250	2.38	11.5		54	0.5	820 × 820	3040	1810 × 920 × 1735	2200 × 1650 × 2200	
1600	2.79	13.8		54	0.5	820 × 820	3810	1870 × 920 × 1955	2200 × 1650 × 2200	
2000	3.24	16.3		56	0.5	1070 × 1070	4440	2000 × 1150 × 2045	2500 × 1800 × 2400	
2500	3.87	19.3		60	0.5	1070 × 1070	5510	2190 × 1150 × 2075	2500 × 1800 × 2400	
2000	3.24	17.8		8	56	0.5	1070 × 1070	4600	2050 × 1150 × 2100	2500 × 1800 × 2400
2500	3.87	21.2			60	0.5	1070 × 1070	5730	2240 × 1220 × 2130	2800 × 1800 × 2500
3150	4.6	25.2	62		0.5	1070 × 1070	6810	2320 × 1250 × 2180	2900 × 1900 × 2600	
3500	4.98	27.2	64		0.5	1070 × 1070	7360	2400 × 1280 × 2250	2900 × 1900 × 2600	

**Remark:** Eaton reserves the right to make changes or modify the contents of this catalogue without prior notice.  
Eaton CRT can be designed and manufactured as per GB/IEC/ANSI standards.

# Product Electrification Criteria

## 35kV Class 200 ~ 3500kVA Distribution Transformer ( Copper Winding )

HV Voltage: 33kV/34.5kV/35kV /37kV  
 LV Voltage: 400V/415V/420V/433V  
 Frequency: 50Hz/60Hz

HV tapping:  $\pm 2*2.5\% / \pm 5\%$   
 Vector group: Dyn11/Dyn5/Dyn1/Yyn0  
 Material of winding: Copper

Rated Power (KVA)	No-load Loss (kW)	On-load Loss 120°C (kW)	Short Circuit Impedance (%)	Noise (Lm-1) (dB)	No-load Current (%)	Base Frame Q1XQ2 (mm)	Weight (kg)	Outline Dimension (LengthxWidthxHeight) (mm)	Enclosure Dimension (IP20/IP21) (LengthxWidthxHeight) (mm)	
200	0.88	3.32	6	50	1.1	660 × 660	1480	1520 × 760 × 1680	2300 × 1800 × 2200	
250	0.99	3.80		50	1.1	660 × 660	1760	1580 × 760 × 1740	2300 × 1800 × 2200	
315	1.17	4.51		50	1	820 × 820	1980	1680 × 920 × 1660	2300 × 1800 × 2200	
400	1.37	5.41		50	1	820 × 820	2280	1760 × 920 × 1700	2500 × 1800 × 2200	
500	1.62	6.65		50	1	820 × 820	2480	1800 × 920 × 1720	2500 × 1800 × 2200	
630	1.86	7.69		50	0.85	820 × 820	2900	1880 × 920 × 1800	2500 × 1800 × 2200	
800	2.16	9.12		52	0.6	820 × 820	3380	1920 × 920 × 1900	2600 × 2000 × 2400	
1000	2.43	10.40		52	0.6	820 × 820	3680	1980 × 920 × 1920	2600 × 2000 × 2400	
1250	2.83	12.70		54	0.5	820 × 820	4280	2040 × 920 × 1960	2700 × 2000 × 2400	
1600	3.24	15.40		56	0.5	1070 × 1070	5230	2120 × 1150 × 2040	2700 × 2000 × 2400	
2000	3.82	18.20		58	0.5	1070 × 1070	5980	2240 × 1150 × 2080	2900 × 2200 × 2600	
2500	4.45	21.80		60	0.5	1070 × 1070	6640	2300 × 1150 × 2200	2900 × 2200 × 2600	
3150	5.29	28.50		8	64	0.5	1070 × 1070	8070	2400 × 1250 × 2300	3200 × 2300 × 2700
3500	5.72	30.80			68	0.5	1070 × 1070	8730	2480 × 1280 × 2380	3200 × 2300 × 2700

## 35kV Class 200 ~ 3500kVA Distribution Transformer ( Aluminum Winding )

HV Voltage: 33kV/34.5kV/35kV /37kV  
 LV Voltage: 400V/415V/420V/433V  
 Frequency: 50Hz/60Hz

HV tapping:  $\pm 2*2.5\% / \pm 5\%$   
 Vector group: Dyn11/Dyn5/Dyn1/Yyn0  
 Material of winding: Aluminum

Rated Power (KVA)	No-load Loss (kW)	On-load Loss 120°C (kW)	Short Circuit Impedance (%)	Noise (Lm-1) (dB)	No-load Current (%)	Base Frame Q1XQ2 (mm)	Weight (kg)	Outline Dimension (LengthxWidthxHeight) (mm)	Enclosure Dimension (IP20/IP21) (LengthxWidthxHeight) (mm)	
200	0.88	3.32	6	50	1.1	660 × 660	1330	1540 × 760 × 1720	2300 × 1800 × 2200	
250	0.99	3.80		50	1.1	660 × 660	1590	1600 × 760 × 1780	2300 × 1800 × 2200	
315	1.17	4.51		50	1	820 × 820	1790	1700 × 920 × 1690	2300 × 1800 × 2200	
400	1.37	5.41		50	1	820 × 820	2180	1820 × 920 × 1780	2500 × 1800 × 2200	
500	1.62	6.65		50	1	820 × 820	2280	1860 × 920 × 1750	2500 × 1800 × 2200	
630	1.86	7.69		50	0.85	820 × 820	2580	1920 × 920 × 1820	2600 × 2000 × 2200	
800	2.16	9.12		52	0.6	820 × 820	3140	1980 × 920 × 1940	2600 × 2000 × 2400	
1000	2.43	10.40		52	0.6	820 × 820	3280	2020 × 920 × 1960	2700 × 2200 × 2400	
1250	2.83	12.70		54	0.5	820 × 820	3690	2080 × 920 × 1980	2700 × 2200 × 2400	
1600	3.24	15.40		56	0.5	1070 × 1070	4920	2180 × 1150 × 2090	3000 × 2200 × 2500	
2000	3.82	18.20		58	0.5	1070 × 1070	5580	2280 × 1150 × 2120	3000 × 2200 × 2500	
2500	4.45	21.80		60	0.5	1070 × 1070	6170	2400 × 1150 × 2280	3100 × 2200 × 2700	
3150	5.29	28.50		8	64	0.5	1070 × 1070	7630	2480 × 1250 × 2360	3100 × 2400 × 2800
3500	5.72	30.80			68	0.5	1070 × 1070	8260	2580 × 1300 × 2480	3100 × 2400 × 2800

**Remark:** Eaton reserves the right to make changes or modify the contents of this catalogue without prior notice.  
 Eaton CRT can be designed and manufactured as per GB/IEC/ANSI standards.

## 35kV Class 4000 ~ 25000kVA Power Transformer ( Copper Winding )

HV Voltage: 33kV/34.5kV/35kV /37kV  
 LV Voltage: 6kV/6.3kV/10kV /11kV  
 Frequency: 50Hz/60Hz

HV tapping:  $\pm 2 \times 2.5\%$  /  $\pm 5\%$   
 Vector group: YNd11/ Yd11/ Dyn11/Yyn0  
 Material of winding: Copper

Rated Power (KVA)	No-load Loss (kW)	On-load Loss 120°C (kW)	Short Circuit Impedance (%)	Noise (Lm-1) (dB)	No-load Current (%)	Base Frame Q1XQ2 (mm)	Weight (kg)	Outline Dimension (LengthxWidthxHeight) (mm)	Enclosure Dimension (IP20/IP21) (LengthxWidthxHeight) (mm)
4000	7.02	29.4	8	64	0.70	1475 × 1070	10555	3230 × 1400 × 2100	4000 × 2400 × 3000
5000	8.37	34.9		66	0.60	1475 × 1070	12850	3300 × 1400 × 2250	4000 × 2400 × 3000
6300	9.9	40.8		66	0.60	1475 × 1070	16765	3505 × 1400 × 2330	4200 × 2400 × 3000
8000	11.3	46.0	9	68	0.50	1475 × 1475	18400	3755 × 1800 × 2700	4500 × 2800 × 3200
10000	12.9	55.5		68	0.50	2040 × 1475	22200	3900 × 1800 × 2950	4600 × 2800 × 3500
12500	15.7	64.6		70	0.40	2040 × 1475	28000	4095 × 1800 × 3040	4800 × 2800 × 3500
16000	19.3	76.0		70	0.40	2040 × 1475	31000	4105 × 1800 × 3100	4800 × 3000 × 3600
20000	22.9	85.5	10	74	0.35	2040 × 1475	34800	4295 × 1800 × 3200	5000 × 3000 × 3600
25000	27.1	101.0		74	0.35	2040 × 1475	38000	4400 × 1800 × 3400	5200 × 3000 × 3800

## 35kV Class 4000 ~ 25000kVA Power Transformer ( Aluminum Winding )

HV Voltage: 33kV/34.5kV/35kV /37kV  
 LV Voltage: 6kV/6.3kV/10kV /11kV  
 Frequency: 50Hz/60Hz

HV tapping:  $\pm 2 \times 2.5\%$  /  $\pm 5\%$   
 Vector group: YNd11/ Yd11/ Dyn11/Yyn0  
 Material of winding: Aluminum

Rated Power (KVA)	No-load Loss (kW)	On-load Loss 120°C (kW)	Short Circuit Impedance (%)	Noise (Lm-1) (dB)	No-load Current (%)	Base Frame Q1XQ2 (mm)	Weight (kg)	Outline Dimension (LengthxWidthxHeight) (mm)	Enclosure Dimension (IP20/IP21) (LengthxWidthxHeight) (mm)
4000	7.02	29.4	8	64	0.70	1475 × 1070	9600	3300 × 1400 × 2300	4100 × 2400 × 3000
5000	8.37	34.9		66	0.60	1475 × 1070	11600	3380 × 1400 × 2555	4100 × 2400 × 3000
6300	9.9	40.8		66	0.60	1475 × 1070	15200	3580 × 1400 × 2730	4200 × 2400 × 3200
8000	11.3	46.0	9	68	0.50	1475 × 1475	16600	3840 × 1800 × 2800	4500 × 2800 × 3200
10000	12.9	55.5		68	0.50	2040 × 1475	20800	3980 × 1800 × 3150	4700 × 2800 × 3500
12500	15.7	64.6		70	0.40	2040 × 1475	25800	4160 × 1800 × 3240	4900 × 2800 × 3500
16000	19.3	76.0		70	0.40	2040 × 1475	27900	4200 × 1800 × 3260	4900 × 3000 × 3600
20000	22.9	85.5	10	74	0.35	2040 × 1475	31800	4380 × 1800 × 3380	5100 × 3000 × 3800
25000	27.1	101.0		74	0.35	2040 × 1475	35000	4600 × 1800 × 3500	5300 × 3000 × 4000

**Remark:** Eaton reserves the right to make changes or modify the contents of this catalogue without prior notice.  
 Eaton CRT can be designed and manufactured as per GB/IEC/ANSI standards.

## Design

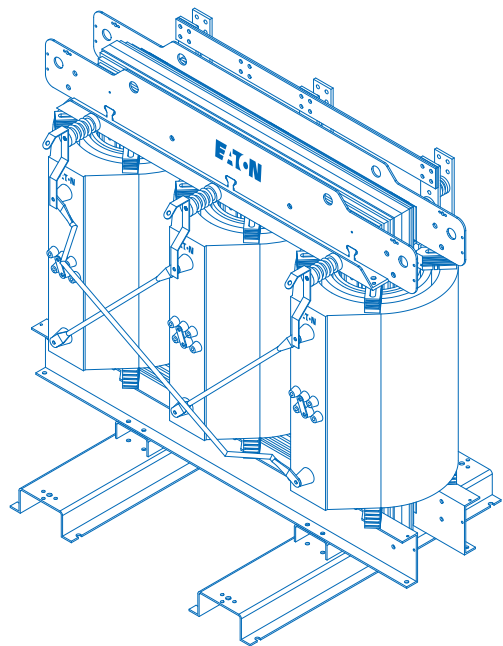
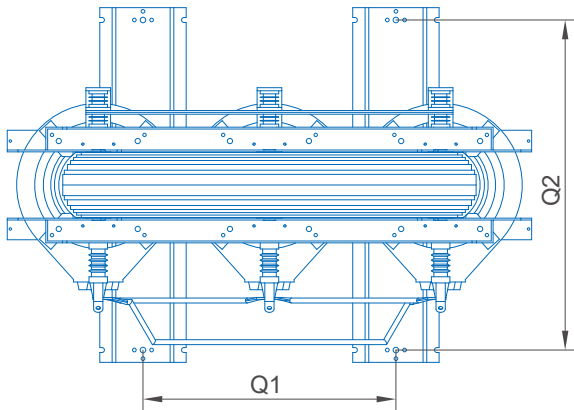
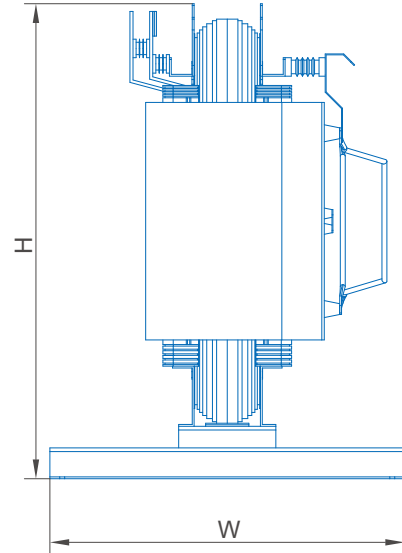
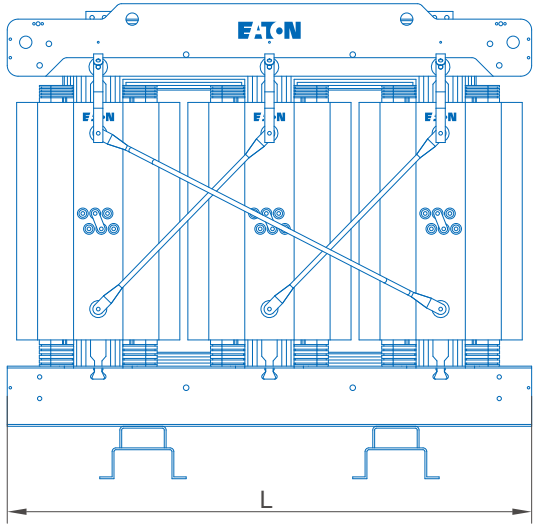



Healthcare

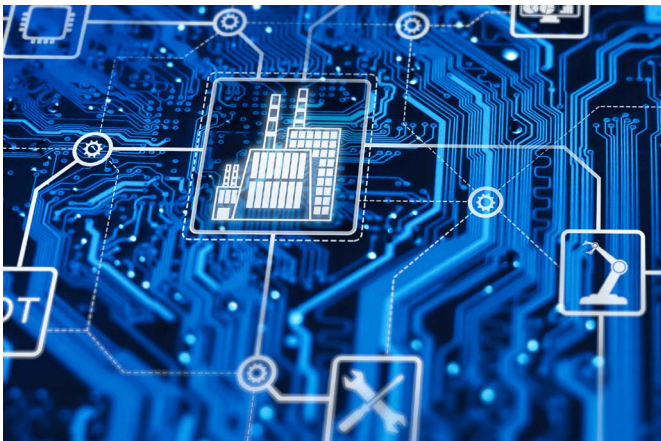

Data center



Industry



Commercial buildings



Utilities



Renewable energy

Eaton is an intelligent power management company dedicated to improving the quality of life and protecting the environment for people everywhere. We are guided by our commitment to do business right, to operate sustainably and to help our customers manage power - today and well into the future. By capitalizing on the global growth trends of electrification and digitalization, we're accelerating the planet's transition to renewable energy, helping to solve the world's most urgent power management challenges, and doing what's best for our stakeholders and all of society.

Eaton was founded in 1911 and has been listed on the New York Stock Exchange since 1923. We reported revenues of \$20.8 billion in 2022 and serve customers in more than 170 countries. Eaton entered the Chinese market in 1993 and has grown significantly since then. In 2004, Eaton moved its Asia-Pacific headquarters from Hong Kong to Shanghai. Today, Eaton has nearly 9,000 employees and 20 manufacturing facilities in China. Eaton is marking its 100th anniversary of being listed on the New York Stock Exchange, and its 30th anniversary of being in Chinese market.

**Eaton Corporation**

No.3, Lane 280. Linhong Road.  
Changning District,  
Shanghai, China 200335

**Eaton Transformer (Jiangsu) Co., Ltd.**

No. 88-9, West Changjiang Road,  
Haian, China 226600

© 2023 Eaton Corporation  
All Rights Reserved  
Printed in China  
June 2023